



HEAD OFFICE:

2001 ALBION RD., UNITS 17-20, TORONTO, ON CANADA M9W 6V6
TEL: 416-674-2552 FAX: 1-888-329-2910

www.gateway-graphics.com E-MAIL: sales@gateway-graphics.com

WESTERN OFFICE:

3721 BONNINGTON ROAD, BONNINGTON, BC CANADA V0G 2G3
TEL: 250-359-5083 FAX: 250-359-5084
E-MAIL: peobrien@shaw.ca



Serving North America's Lumber, Panel & Wood Packaging Industries

Product List

Grade Stamps, Strips and Bands	1
Lumber Marking Ink	2
Pre-inked Rolls	3
Dry Ink Rolls	3
Wood and Metal Mounts	4
- Wood Mounts	4
- 3-Way Mounts	4
- Metal Rocker Mounts	4
End Stamping and Edge Marking	4
Gateway Stamping Hammers	5
- Pressure Fit, Plate Backed, Plain or Velcro	5
Pre-Inked & Dry Pads	5
GHC Hand Printers	6
HP-100- HP 200 Hand Printers.....	7
G-22 Printer for Plywood, OSB, E.W.P.	7
G-Series Line Printers	8
- G-9, G-14 and G-29	8
Gateway Stud Printer	9
Automated Panel & OSB Face Grade Printers	10
Automatic Lumber Face Grade Printers	11
Stencil Systems	12
- Aluminum, Mylar, Oilboard Stencils & Bass Interlocking	12
- Stencil Roller Applicators, Ink Roller, Dry Pads & Ink	12
Lumber Crayons and Markers	13
Crayon Holders	13
Grain Scribes	13
Order Form	Back Cover

GRADE STAMPS, STRIPS & BANDS



CLA 869
2100 Fb 1.8E
MSR KD-HT
S-P-F NLGA
CLA 869
2100 Fb 1.8E
MSR KD-HT
S-P-F NLGA
CLA 869
2100 Fb 1.8E
MSR KD-HT
S-P-F NLGA

OLMA® 21
2 KD-HT
S-P-F NLGA
MADE IN CANADA
OLMA® 21
2 KD-HT
S-P-F NLGA
MADE IN CANADA
OLMA® 21
2 KD-HT
S-P-F NLGA
MADE IN CANADA

FRANK LBR
WC LB 1800f 1.8E
1200ft MSR
D. FIR KD 15-HT



US-09526 HT
NELMA®

Norbord
APA
RATED SHEATHING
24/16
SIZE D FOR SPACING
EXPOSURE 1
THICKNESS 0.418 INCH
PS 2-10 SWEATHING
PP-100
HDDUM-40
7/16 CATEGORY
STRENGTH AXIS
EJE DE RESISTENCIA
THIS SIDE DOWN
ESTE LADO ABAJO
ROOF CLIPS
RECOMMENDED
AND MAY BE
REQUIRED
SPACE ALL EDGES 1/8"
DEJE UN ESPACIO
DE 1/8" ENTRE BORDES
-502-
365
2016

CLF S-DRY
198 2
NLGA S-P-F

PRIME
PRIME

HUBER
ZIPsystem
ICC-ES ESR-1473
ICC-ES ESR-2474
CCMC 140204E
SFI
SPACE 1-8 FROM
1/2 20mm AT SQUARE
SELF SPACING ON
PROFILED EDGE
THIS SIDE DOWN
ESTE LADO ABAJO
UL 3PL
MILL 229
TECO
TESTED
PS 2-10 HD 90-90
EXPOSURE 1
SHEATHING SPAN
5/8 Perf. Cat.
40/20
15.5 mm
OSA 0325-16
1802-2040/2120/221
STRENGTH AXIS
THIS DIRECTION
THICKNESS 0.594 IN.

- High quality and deep molded rubber stamps
- Special rubber formulations for increased clarity and durability
- Lumber and panel grade stamps, HT and IPPC stamps, date and shift codes, company logos, etc.
- Single stamps, multiple impressions belts and bands with custom sizing and orientation
- Available in plain, adhesive, Velcro, brass or plate backing
- Our Velcro backed stamps are both professionally sewn and glued with our special glue formulations which resists delaminating of the Velcro from the rubber
- Supplying lumber and panel Grading Agencies throughout North America and the world

特種用合板
特種 JAS
12mm
2級

2016 CCA-C .60 PCF
AUDITED BY
TP®
GROUND CONTACT
AWPA U1 / UC4B
SIMMONS WOOD PRODUCTS
MARIQUA, AZ

167 STIMSON
UTIL
1/4 EE
KD HT

TECO
TESTED
PS 1-30
EXPOSURE 1
FLOOR SPAN
19/32 CATEGORY
UNDERLAYMENT
20 o.c.
TONGUE AND GROOVE
NET FACE 47-5/8"
MILL 339
HOQUIAM PLYWOOD CO. INC.

O-100
ALB NO.2
D.FIR S-GRN

XXXXXX
XXXXXX
XXXXXX
XXXXXX
XXXXXX
XXXXXX

A.F.P.A.® 88
HT

AUDITED BY
TP®
NO.3
696 KDHT
SYP

CSI NO.2
873 KD-HT
NLGA S-P-F
CSI NO.2
873 KD-HT
NLGA S-P-F
CSI NO.2
873 KD-HT
NLGA S-P-F
CSI NO.2
873 KD-HT
NLGA S-P-F
CSI NO.2
873 KD-HT
NLGA S-P-F

SFI
Certified Sourcing
www.sfi-program.org
SFI-00008

S-P-F
KD-HT
2
570 NLGA

US-20272 HT
EWP
DUN

LUMBER MARKING INK



Gateway's Ink Is Specially Formulated By Our Chemist, and Approved By The Engineered Wood Association (APA)

1. No excessive wicking or running
2. Practically odourless
3. Crisp sharp colours
4. Permanent
5. Weather & UV light resistant
6. Shipped as Non-Dangerous goods
7. Available in Black, Red, Green, Yellow & Blue



Gallons
Quarts
Pints



Available in
1qt., 1 gal., 5 gal pail,
55 gal drum, 265 gal tote.

**Ideal for
Inking Stamp Pads
Perfect for
Ink rolls
Can be used
for Stenciling**

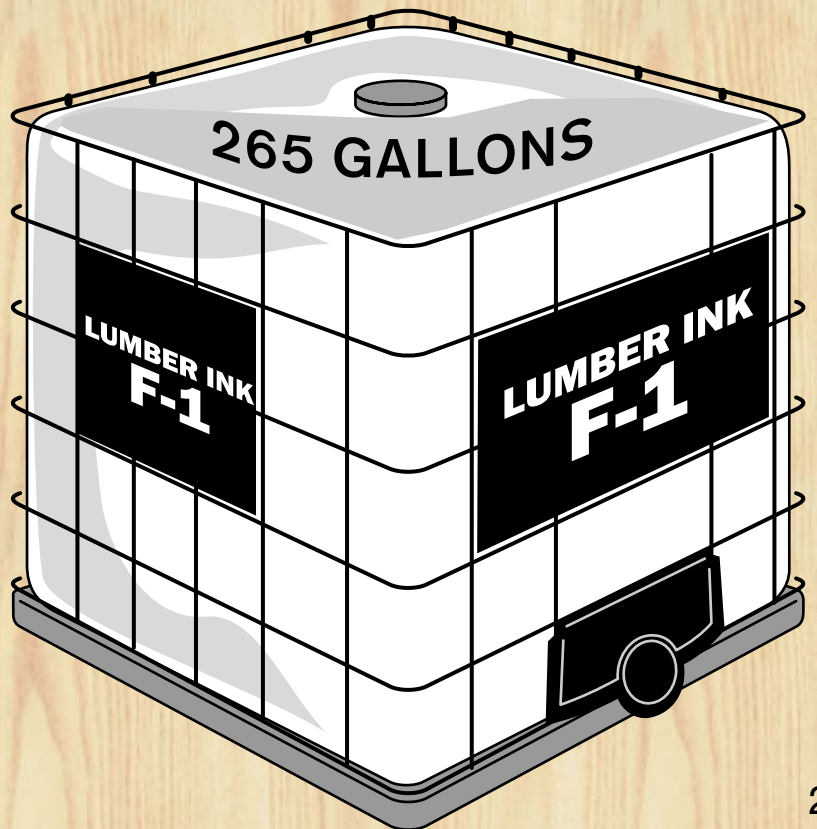

PRE-INKED ROLLS

Approved by the Engineered Wood Association (APA)
for use in the Wood Products industry



- We carry a full range of sizes to fit any grade printing equipment.
- Available in black, red, blue, green and other colours.
- Very soft to extra firm in hardness.
- UV and fade resistant.
- Non-toxic with no harsh fumes or chemicals.

DRY INK ROLLS



- For manual or ink feed marking systems.
- Use with Gateway F-1 black or coloured inks.
- Soft, firm or extra firm rolls for marking with rubber or steel die.
- Available in a full range of sizes.
- Free samples available upon request see sizing diagram

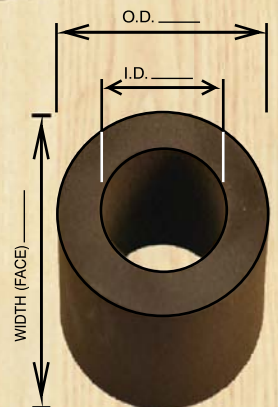

WOOD AND METAL MOUNTS

The 3-way wood mount allows the grader to easily switch between stamps. Available in: 1-1/4" x 3" or 1-1/2" x 3"

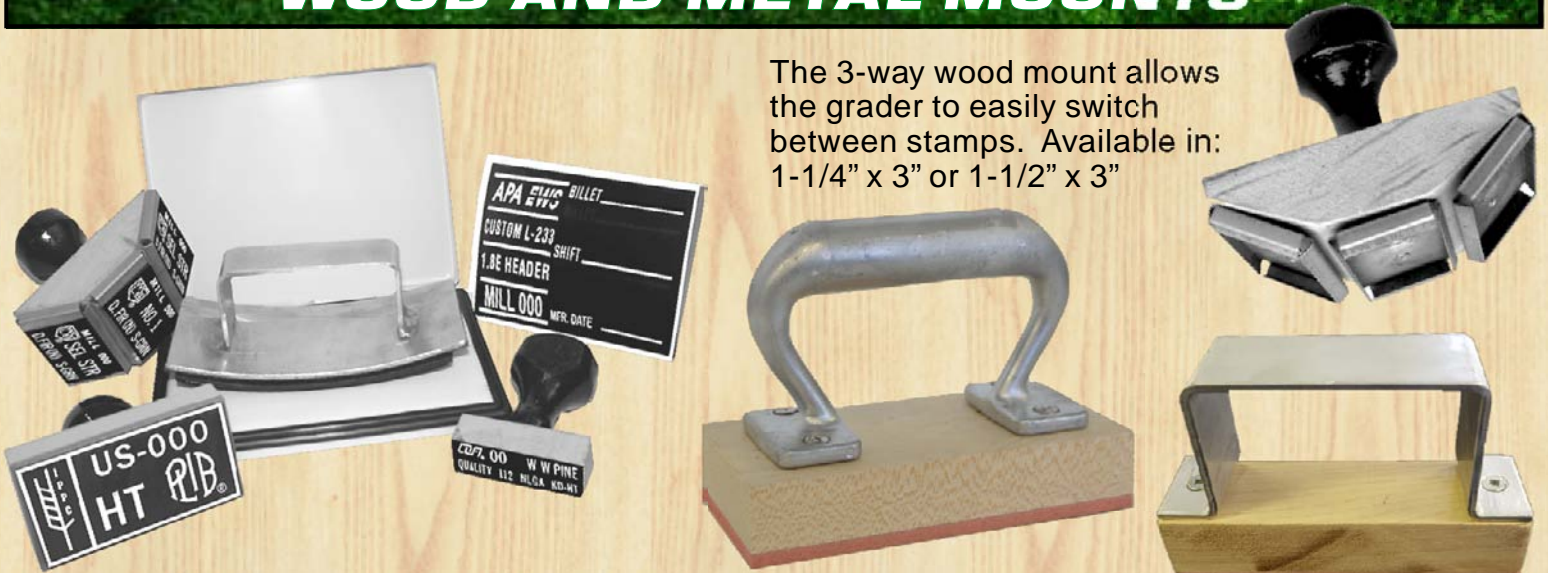

WOOD MOUNTS

Custom cut wood mounts for all applications
A variety of sizes and handles available to suit every need
Rubber die custom made to your specification
Permanently attached, or with Velcro for easy replacement



METAL ROCKER MOUNTS

- Rocker mounts are used for larger stamps for better transfer of impressions
- Stamps can be attached with sticky back, permanent glue or velcro for quick replacement

FOR USE WITH GATEWAY STAMP PADS AND F-1 LUMBER INK

END STAMPING AND EDGE MARKING



Narrow stamps and mounts for end stamping 1" and 2" boards
End rollers for continuous printing on Lumber, Plywood, OSB and Pallets



GATEWAY STAMPING HAMMERS

WELL BALANCED AND LIGHTWEIGHT
DURABLE SOLID RUBBER HEADS WITH HARDWOOD HANDLES
INCLUDES CRAYON HOLDER WITH TIGHTENING RING



Pressure Fit

No glue, no screws, no Velcro; stamps are just squeezed in behind metal tabs and will not come off.



Plain or Velcro

Stamps can be attached permanently on solid rubber heads or for easy replacement using velcro.



Plate Backed

Plate backed stamps simply slide into place and back out for changes.

PRE-INKED & DRY PADS



PRE-INKED STAMP PADS

Heavy duty steel casing for long lasting usage
Replacement pre-inked inserts are available in
Black, Red, Blue & Green.
Available in: 4" x 5-7/8"

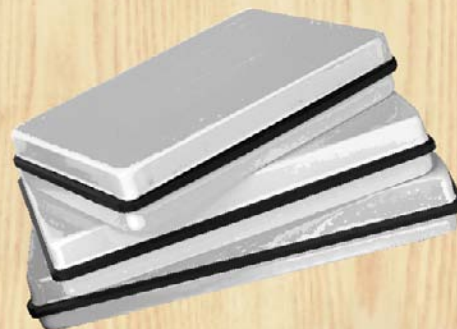

Cloth covered dry stamp pads with
heavy duty steel casing
Available in the following sizes:
4" x 5-7/8"
4-3/4" x 6-3/4"
5-7/8" x 7-7/8"
7-7/8" x 11-3/4"

GHC SERIES HAND PRINTERS

FAST, RELIABLE, CONTINUOUS PRINTING
 LIGHTWEIGHT AND COST EFFECTIVE
 EASY ONE HAND APPLICATION.
 NO MESSY INKS AND STAMP PADS
 DESIGNED FOR THE LUMBER AND PALLET INDUSTRY.



FACE GRADE PRINTING

Gateway's self inking hand printers are the perfect solution for hand held marking of lumber, panels and pallets. The self inking feature allows for rapid continuous printing without the need for messy inks and stamp pads. Pre-inked ink rolls provide up to 40,000 imprints per roll and are available in a variety of colours. The ink transfer rate is easily adjusted in seconds with a turn of the eccentric dial.

Dry ink rolls are also available.

The print drums are available in continuous and indexing models and come pre-mounted with Velcro for quick and easy attachment and removal of stamps. The indexing models utilize a unique cam indexing mechanism to return the print drum to the same starting position when the printer is lifted away from the surface being marked. The index mechanism allows the print drum to rotate 365 degrees before reaching a positive stop. This provides full use of the print area. A cushioned handle provides for a comfortable grip for extended use.



EDGE PRINTING

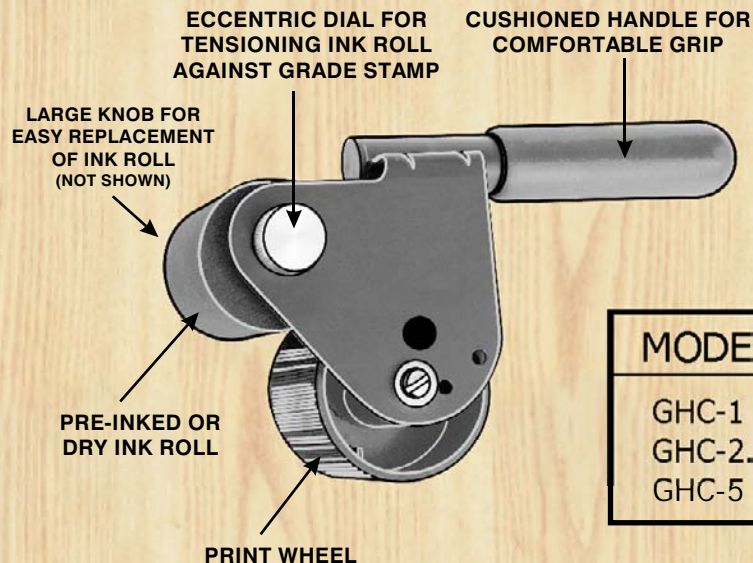

MODEL	PRINT AREA
GHC-1	1-3/4" x 10"
GHC-2.5	2-1/4" x 10"
GHC-5	4-3/4" x 10"

HP-100 & HP-200 HAND PRINTER

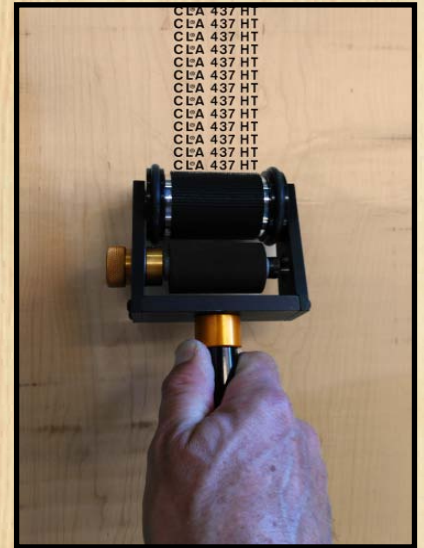

The HP Hand Printers are the perfect solution for applying date codes, lot numbers and other product information where automatic coding is not possible.

These coders feature heavy duty precision machined components made from aircraft grade aluminum alloys, stainless steel mounting columns and shafts and sealed ball bearings for smooth print drum rotation.

Available in both indexing and non-indexing (continuous print) models.

The HP-100NI model features 2" x 6.5" print area.

The HP-200 model features a 2" x 9.1" print area.

Available with Dry Ink Rolls Only.

G-22 PRINTER FOR PLYWOOD, OSB, ENGINEERED WOOD PRODUCTS



The **G-22 Printer** is designed for off-line application of panel stamps. Made with a lightweight aluminum alloy handle. Rolls easily across any panel surface leaving clear, crisp impressions. The rubber cushioned print drum has a print area equal to most industrial line printers and Velcro mount for easy stamp changes. Comes with print wheels of various diameters and widths to fit any size stamp.

G SERIES PRINTERS - (G-9, G-14, G-29)



The **G** series are medium duty Line Printers designed to provide continuous impressions from a friction driven stamp wheel. The stamp hub has a rubber bumper on one side to absorb any shock and allow smooth application of stamp impression.

These printers can be mounted directly Above, Left or on the Right side of the production line. The ink roll assembly snaps on & off with ease for quick, no mess changing of ink rolls.



- DURABLE, BUILT TO LAST FOR YEARS
- PRE-INKED DISPOSABLE INK ROLLS GIVE YOU SHARP CLEAR IMPRESSIONS EVERY TIME, WITH NO LIQUID MESS
- COMPLETE WITH MOUNTING BRACKETS
- DRY FOAM INK ROLLS ALSO AVAILABLE
- VELCRO BACKED STAMPS ENABLE QUICK REPLACEMENT MINIMIZING PRODUCTION DOWN TIME

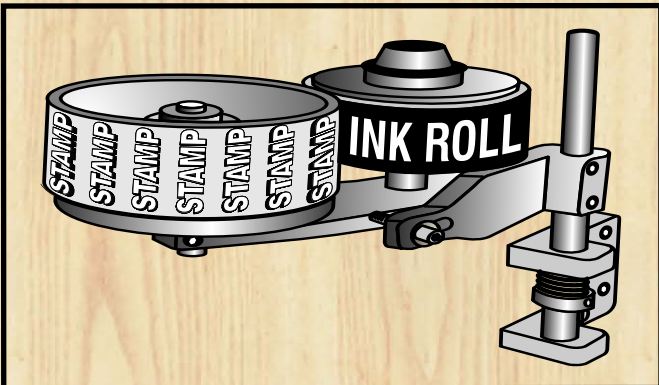

MODEL	PRINT AREA
G-9	7/8" x 16"
G-14	1-5/8" X 16"
G-29	3-3/4" X 16"
G-1.25	7/8" x 16"
G-2	1-5/8" X 16"
G-4	3-3/4" X 16"

GATEWAY STUD PRINTERS

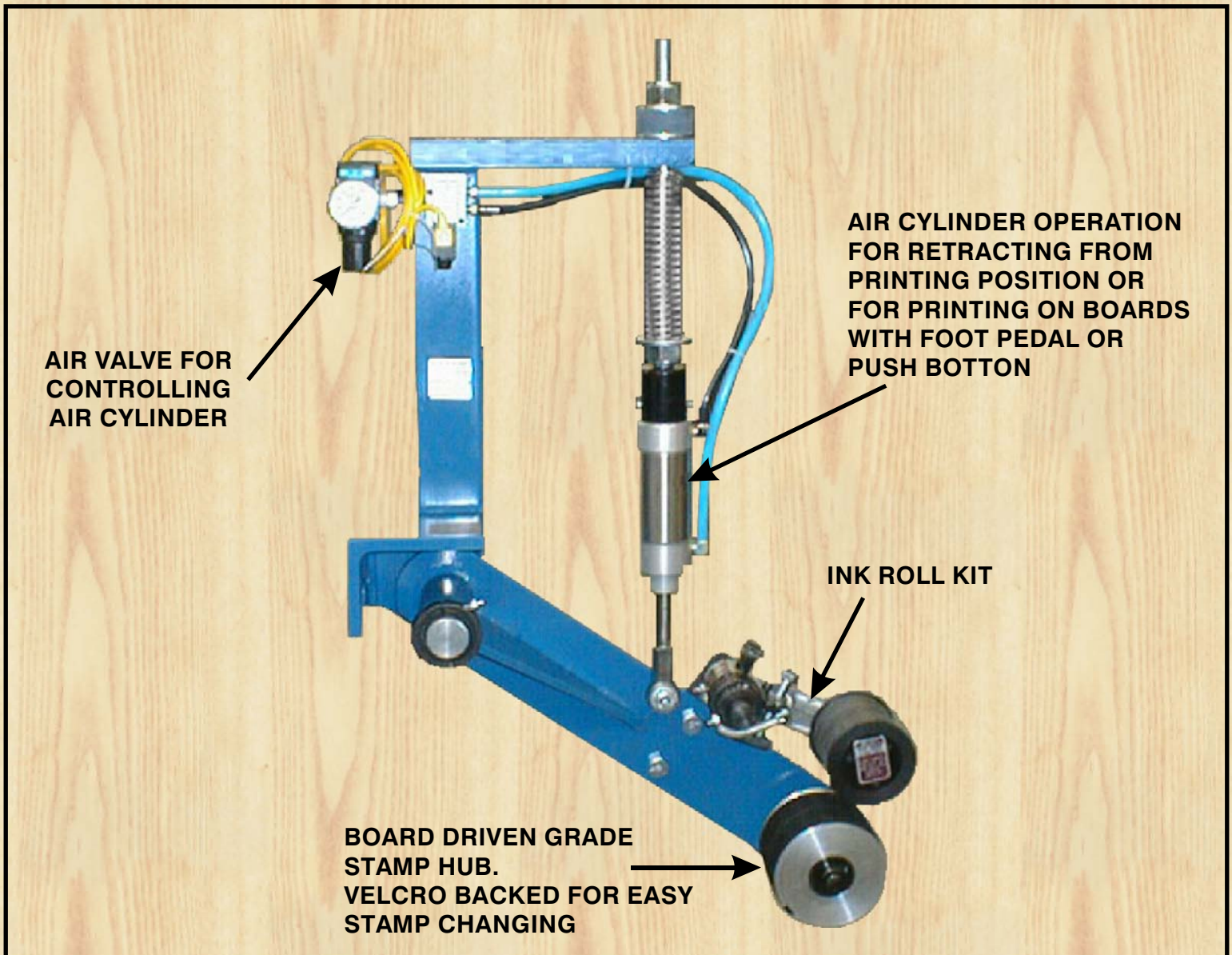

FEATURES

- All steel framework, designed to handle most industrial lumber mill applications.
- Can be mounted above, below or beside your production line.
- Board driven for continuous printing, or
- Air actuated and timed with most grade mark readers. In the air actuated models, a foot pedal, button, or mill PLC is timed to the chain lugs to lift and drop the arm as the boards pass under.
- Stamps attach easily with Velcro or a snug fitting bands.
- Ink is supplied by pre-inked ink rolls or through a specially designed ink flow system.
- Standard size print wheels are 1-1/2", 3", or 6" wide.
- Optional heated ink roll kits can be used to operate year round in cold conditions.

AUTOMATED PANEL & OSB FACE GRADE PRINTERS

STATE OF THE ART — MILLWRIGHT DESIGN

PRE-INKED ROLLS OR A FLO-THRU SYSTEM ARE AVAILABLE

2-1/2" OR 4" DIAMETER INK FLOW KITS

SINGLE OR DUAL CYLINDER AIR DRIVEN FOR MAINTAINING CONSTANT DRUM SPEED TO LINE (OPTIONAL)

ALL PIVOT POINTS HAVE BRASS OILITE BUSHINGS

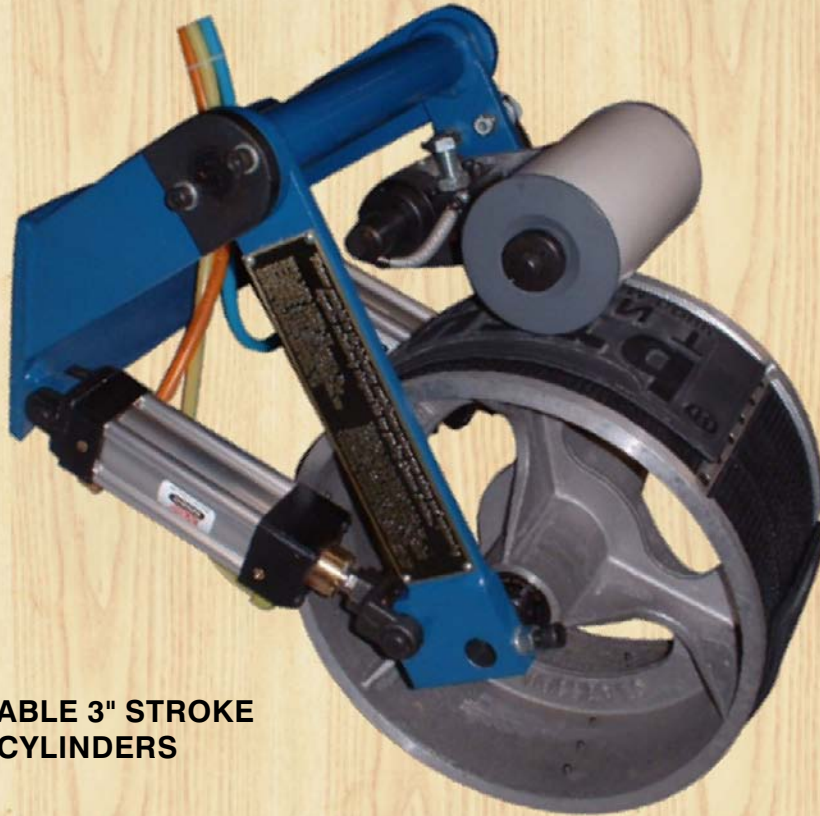

ALL STEEL FRAME

REBUILDABLE 3" STROKE AIR CYLINDERS



BENEFITS / OPTIONS

- All steel frame work, designed for industrial use
- Top or bottom mounting (Optional)
- Dual air cylinders no down time, operates with only one working
- Two large Oilite bushings support both ends of air cylinders
- Board or air driven, maintains the same speed as panels without skidding
- Grade stamps attach easily with Velcro
- Available in 12" and 15" diameter and 1-1/2" to 6" widths
- Stamps are inked by pre-inked rolls or by an Ink-Flo-Thru system
- Optional drum swivel for warped panels
- Optional internal ink roll heater
- Optional wet ink - Flow-Thru System
- #1C - Functions with one air cylinder
- #2C - Two cylinders and dual control panel
- #2Cs - Two air cylinder, dual control panel & drum swivel

 Weyerhaeuser Made in Canada
APA
RATED SHEATHING 24/16 SIZED FOR SPACING EXPOSURE 1 THICKNESS 0.418 IN
533 PS 2-10 SHEATHING PRP-108 HUD-UM-40C 7/16 CATEGORY
CONSTRUCTION SHEATHING 1R24/2F16/W24 11.0 mm CSA O325-16 EXTERIOR TYPE ADHESIVE
 SFI Certified Sourcing www.sfiprogram.org SFI-00008
↑ STRENGTH AXIS THIS DIRECTION ↓
woodbywy.com
THIS SIDE DOWN

AUTOMATIC LUMBER FACE GRADE PRINTER

Lowest maintenance and operating costs in the industry

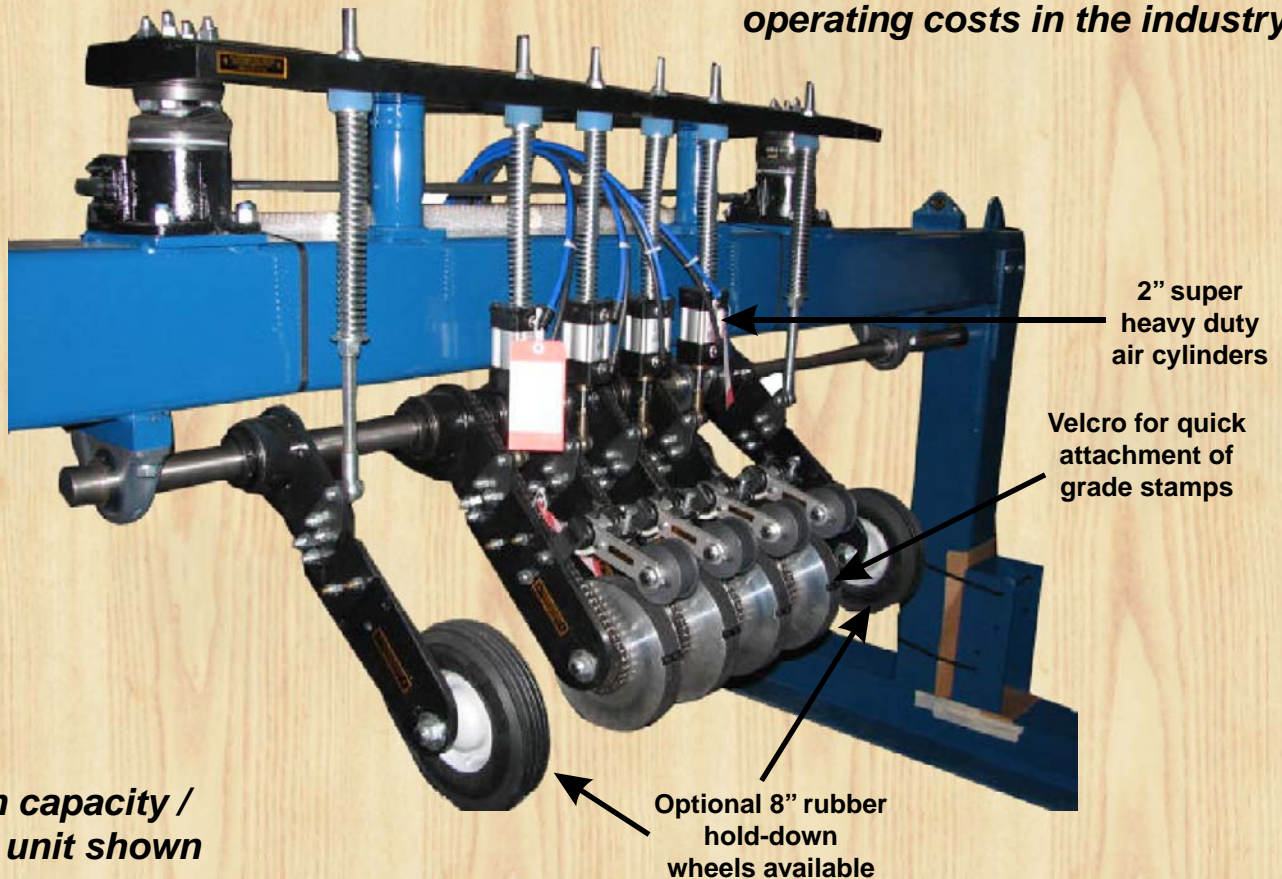

FEATURES

- Computer controlled, multiple grade system
- All steel frame work, millwright designed for industrial use
- 5" clearance above boards for unobstructed clearance of warped or twisted boards. No double stamping
- Strain relief bending plates to protect against damage to Drive Shaft, Arm and Arm bearings
- 100% Ball Bearings
- 100% Taper Locks - no set screws
- Grade stamps attach easily with Velcro, or as snug fitting bands
- Stamps are inked by pre-inked rolls or by an Ink-Flo system
- Burelbach, Hemco and Irvington Moore conversion arms available
- Optional thickness adjuster, adjust all arms simultaneously
- Optional patented internal ink roll heaters



STENCIL SYSTEMS

STENCILS

ALUMINUM



Custom cut aluminum, all sizes and thickness
 Company logos, names and numbers
 Durable and long lasting

MYLAR



Lightweight durable and flexible, designed to your specifications. Can be easily cleaned with solvents.
 Reusable stencil is very durable with a .014 milky white appearance.

OILBOARD



Quick, inexpensive, disposable
 Custom cut or blanks available
 .015 thick oil treated tag board

BRASS INTERLOCKING



Letters slide together and come apart easily for quick legible stencilling on all surfaces
 Use with brush, spray, rollers or markers

APPLICATION SYSTEMS

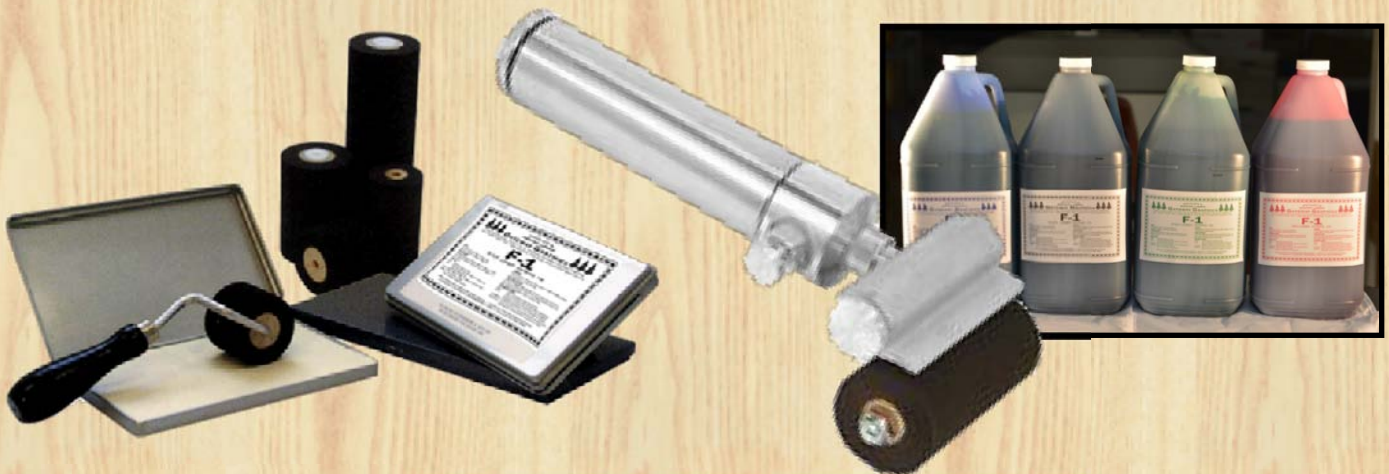

Foam rollers: 1-1/2", 3" or 5"
 Dry stamp pads: 3" x 5" up to 8" x 12"
 F-1 Lumber Ink: Black, Blue, Red, Green
 Pint, Quart, Gallon and Pail

Self-inking Push Button Fountain Roller
 Ink is contained in the roller handle and pumped with a push-button motion
 F-1 Lumber ink in all colors and quantities

LUMBER CRAYONS AND MARKERS



LUMBER CRAYONS

Available in 1/2" hex or 11/16" round size
 Regular and Fluorescent crayons for use with grade mark readers
 Brands including Dixon, Markal, Pro-Ex, Scan-It Plus, Ultrascan
 Railroad Chalk, Paint Sticks, Markers and other items available.



VALVE ACTION IS A LIQUID PAINT MARKER

- 14 standard and 4 fluorescent colours for improved mark identification, quality control, and parts inspection.
- Fast-drying, permanent paint for immediate handling, reduces work downtime
- Xylene-free paint reduces user health risks.



Crayon Holders
 Hardwood Construction
 Protects crayon from breakage
 Comes with leather wrist thong.

- # 112 11/16" Round
- # 109 1/2" Hex

Prograde 11/16"



DURA-INK Marker

Formulated to dry quickly and leave bold, highly-visible marks, the industrial grade ink is safe for use on almost any surface and is smear and water resistant.



GRAIN SCRIBES

A must for determining slope of grain in lumber grading and log home building. Our grain scribes are made of precision cut brass with hardened steel pin for dependable long term use.



Comes in a convenient storage sleeve

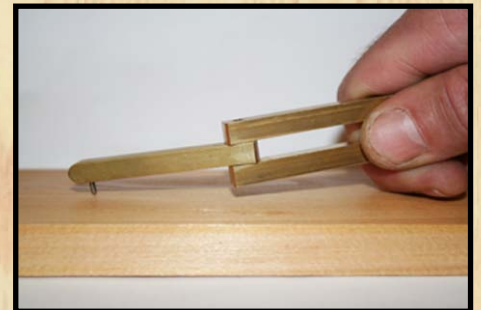

GATEWAY GRAPHICS ORDER FORM

INVOICE TO

SHIP TO

CO. NAME: _____

CO. NAME: _____

ADDRESS: _____

ADDRESS: _____

TEL: _____

ATTN: _____

FAX: _____

INSTRUCTIONS: _____

DATE: _____ P.O. # _____ TAX ID #: _____

QTY.	DESCRIPTION

**PLEASE FAX A COPY OF THIS TO 1-888-329-2910
or E-Mail: sales@gateway-graphics.com**